

BWD[®]

OIL FILTER HOUSING KITS

WHAT'S IN YOUR BOX?™

HERE IS WHAT'S IN OURS

Completely Assembled

Inside the BWD® box, you'll find an Oil Filter Housing Kit that is factory-assembled. Each housing includes a new oil pressure sensor, oil temperature sensor, oil cooler, the correct year/make/model-specific oil filter, new gaskets and seals already installed. Our Oil Filter Housing Kits also include the intake manifold gaskets needed for a complete repair.



Design Improvements

The original oil filter housings on the Pentastar V6 are known for their high failure rates. There are multiple weak points in the original design where oil can leak. Our engineers evaluated the original units and designed housings with multiple improvements over the original to address the OE weak points.



Correct Cooling

Our Oil Filter Housings are designed to match the thermal characteristics of the original design. This is critical as these housings are not only oil filters, but also oil coolers. When the OE developed the oil cooling system to use a high-temp synthetic housing, that is what we deliver, and when the OE uses aluminum, we use aluminum.



Correct Offering

While different generations of Pentastar oil filter housings do look the same, there are functional differences in their design. BWD® always matches OE design and performance by using oil filters with the correct flow rate and the correct oil pressure sensors. Universal housings may not match OE performance for every vehicle model-year that they are cataloged for.



Pentastar Oil Filter Housings

While oil filter housings on Pentastar V6 engines may all look similar, there are distinct differences from year to year, like oil pressure sensors, oil filters, flow rates, and lack of a temperature sensor on late-model applications. Universal designs may not be correct for every application!



BWD® PN	EFH100	EFH101	EFH103	EFH104	EFH111
OEM PN	05184294AE	68105583AF	68310865AC	68365925AD	68365931AD
Year Range	2011-2013	2014-2016	2017-2019	2019-2022*	2022*-2023
OEM Oil Pressure Sensor	5149062AA	5149062AA	68295556AA	68334877AA	68334877AA
OEM Oil Temp Sensor	5149077AB	5149077AB	5149077AB	5149077AB	None
OEM Oil Filter	805036493	805036488	805036488	805036488	805036488
Oil Filter Flow Rate	12L / Minute	10L / Minute	10L / Minute	10L / Minute	10L / Minute

**Varies by actual vehicle make & model*

They don't just filter the oil, they also cool it

Modular oil filter housings are becoming increasingly popular on modern vehicles replacing the older spin-on style filters. It is important to remember, they don't just filter the oil, they also cool it!

- Housings contain passages for both oil and coolant
- These passages are very close together – one failed seal can cause cross-contamination
- It is critical that a replacement unit matches the thermal characteristics of the original design to help keep the oil cool

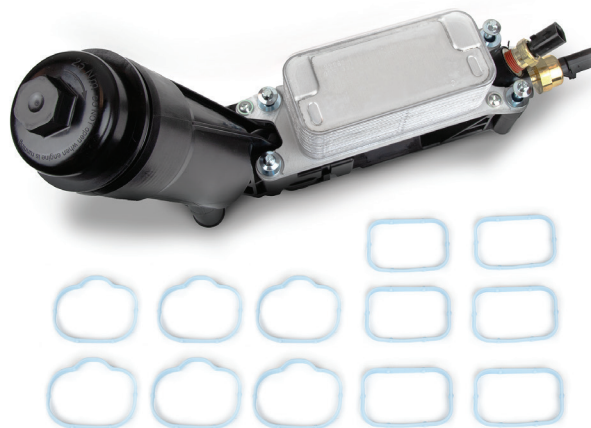

OE Problem:

Oil leaks from the back of the housing around the core plugs that are installed without any seals or O-rings.



BWD Solution:

BWD® installs an O-ring on each core plug before ultrasonically welding them into the housing. This creates a positive, long-lasting seal.

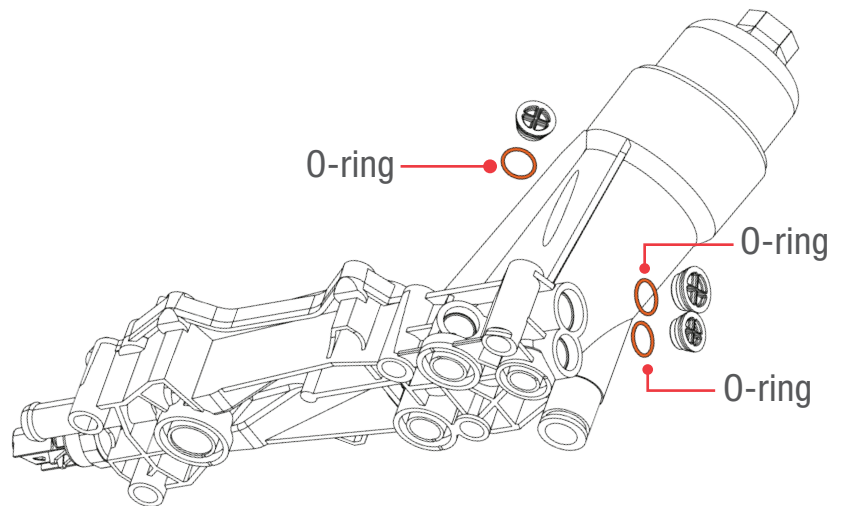

OE Problem:

Oil contaminates the coolant causing cooling system problems, resulting in overheating and premature radiator failure. This is because there is no seal on the core plug that separates the oil and coolant passages.

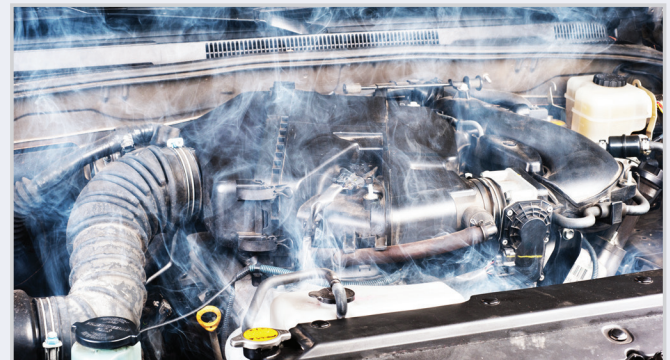

BWD Solution:

We added a robust seal to the core plug which separates these two passages. This enhancement prevents an internal failure and cross-contamination.



OE Problem:

Oil leaks from the brass sensor inserts because there is not an effective seal between the brass and the synthetic housing material.



BWD Solution:

Additional O-rings are installed on our knurled brass inserts to prevent oil leaks.

The sensors are then installed and torqued to specification in a controlled, contaminant-free environment.

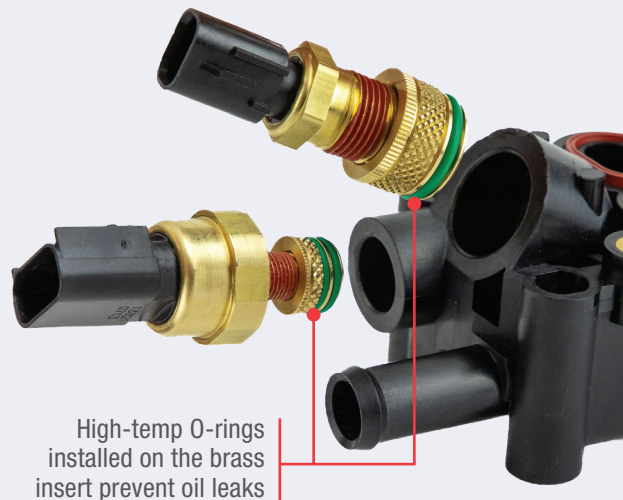

OE Problem:

The OE seals often become distorted or crushed, resulting in an oil leak around the base of the housing.

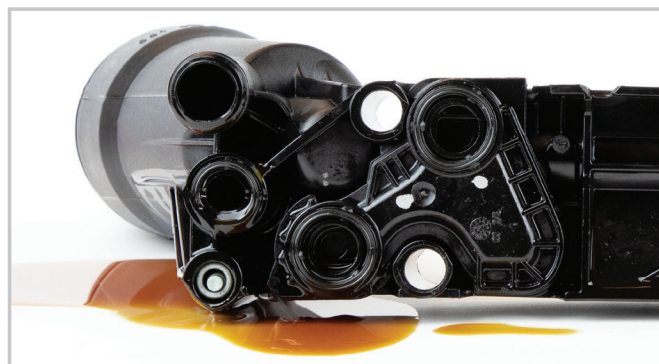

BWD Solution:

We install new, distortion-resistant seals. The synthetic material on the seals is less prone to failure than the original.

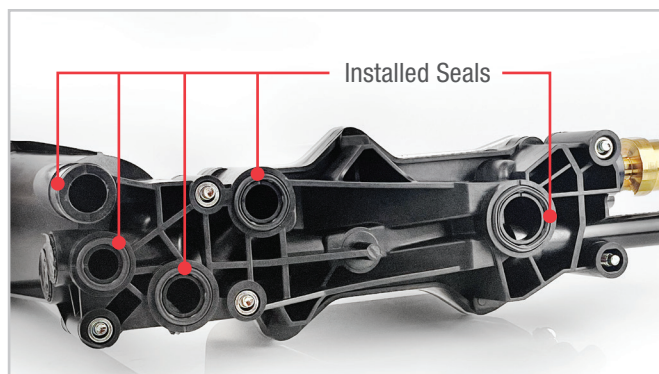

THE FACTORY-ASSEMBLED, DROP-IN SOLUTION

New cap and O-ring prevent future oil leaks

Correct, vehicle-specific oil filter keeps oil free of debris

Helps keep the oil at OE-designated operating temperatures for performance and reliability

O-rings and gaskets included for a complete and effective repair

Oil temperature sensor is made of high-quality materials to withstand extreme conditions and tested for performance and reliability

Complete gasket set prevents oil leaks

High-strength, high-temp synthetic housing to match OE heat-dissipating characteristics

Oil pressure sensor is computer-calibrated to ensure accurate oil pressure readings

All of the components are 100% new and come assembled from the factory

BWD® EFH100
Chrysler / Dodge / Jeep / RAM (2013-11)

In addition to five different housings for the Pentastar V6, we also offer Oil Filter Housings and Oil Coolers for other import and domestic vehicles.

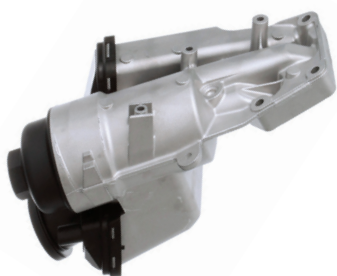

EFH106
Volvo Cars & SUVs (2016-04)
VIO: 206K

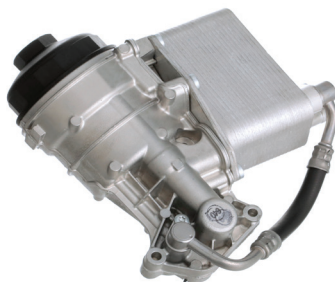

EFH107
Volvo Cars & SUVs (2014-07)
VIO: 87K

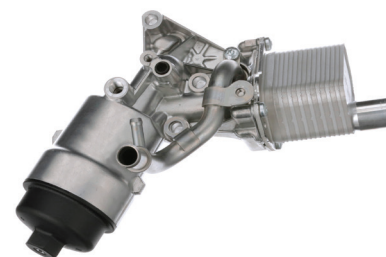

EFH109
Buick / Chevrolet Cars (2021-11)
VIO: 2.2M



BWDBrand.com